

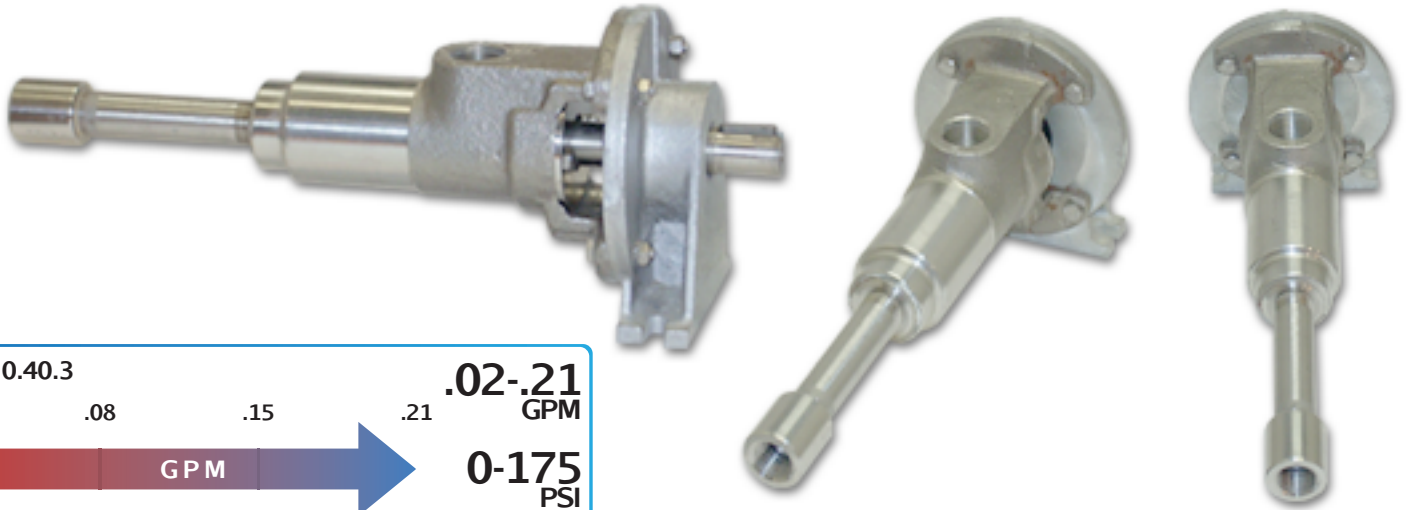

ADPL SERIES - 0.40.3

Progressive Cavity Pump for Metering & Dosing



ADPL 0.40.3

.02 .08 .15 .21

.02-.21
GPM

GPM

0-175
PSI

Features

- Accurate Flow
- Close Coupled
- No Pulsation
- No Check Valves
- Fits in Small Spaces
- Handles High Discharge Pressures

Materials

Rotor: Chrome Plated 316 Stainless Steel

Stator: Buna, Viton™

Motor: 1/2 hp

Inlet: 3/4"

Outlet: 3/4"

Bases: Steel and Stainless Steel

Pump Description

The ADPL 0.40.3 Series of small Low Flow High Pressure Progressive Cavity Metering Pumps from Liberty Process Equipment offers an ideal solution to many low-flow pumping applications that require high accuracy in volume control such as polymer feed for industrial sewage treatment at an affordable price. For liquids that are low-viscosity to high-viscosity and abrasive liquids it provides a pumping solution that is much more reliable than other types of metering pumps available on the market today.

Small piston-type metering pumps with check valves have inherent problems of pulsation, sticking and ball check valves sticking and failing. The Liberty ADPL Series solves all of these problems with pulsation free flow, no check valves required and able to handle viscosities up to 20,000 CP. In addition, with its high-accuracy and repeatability it offers a cost-effective alternative to higher-priced "accurate" metering pumps.

All ADPL pumps are available in cast iron and more popular 316 Stainless Steel materials of all wetted parts and are ready to ship same-day from our facility. A wide variety of motors and controls are available for the ADPL from Liberty Process Equipment to meet your exact control needs and budget. All ADPL pumps have a 3/4" NPT female connections. Discharge connections for the ADPL 0.40.3 are 1" NPT Female.

Liberty Process can offer a drive and control option to meet your needs and budget. From a single fixed spaced rotor in AC or DC to a single hand dial to vary the speed to a remote control PLC, Liberty Process Equipment has your low-flow pumping solutions ready to ship same day. Contact us today for a quote and see the difference the ADPL 0.40.3 can make in your low-flow pumping applications.

Curves

[Click Links Below](#)

3-Stage
ADPL
0.40.3

Drawings

[Click Links Below](#)

3-Stage
ADPL
0.40.3

P: 847.640.7867 F: 847.640.7855
2525 Clearbrook Drive Arlington Heights, IL 60005

www.libertyprocess.com



ADPL SERIES - 0.40.3

Progressive Cavity Pump

Performance Curves

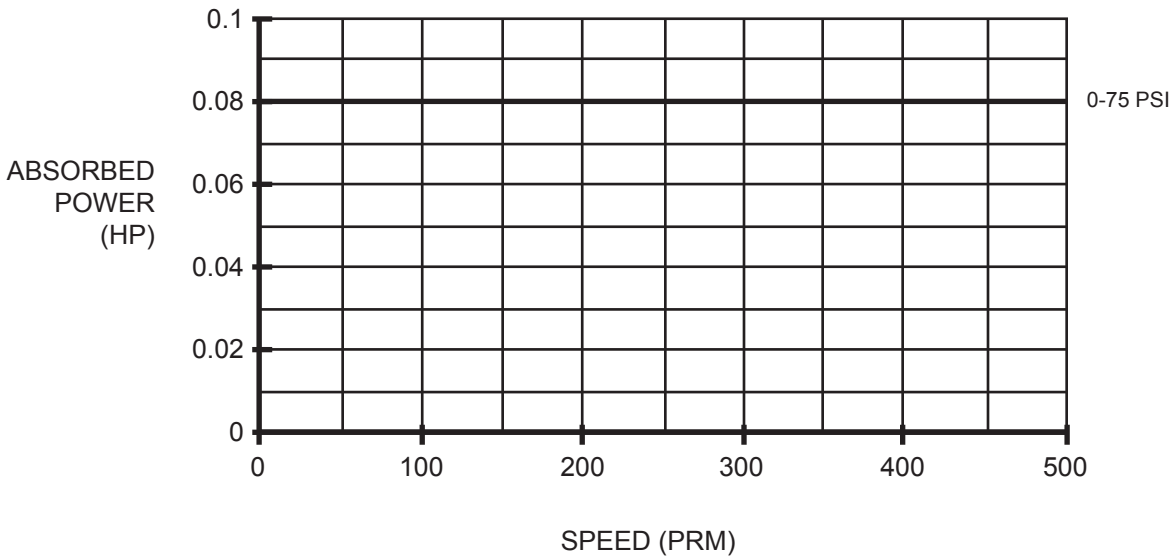
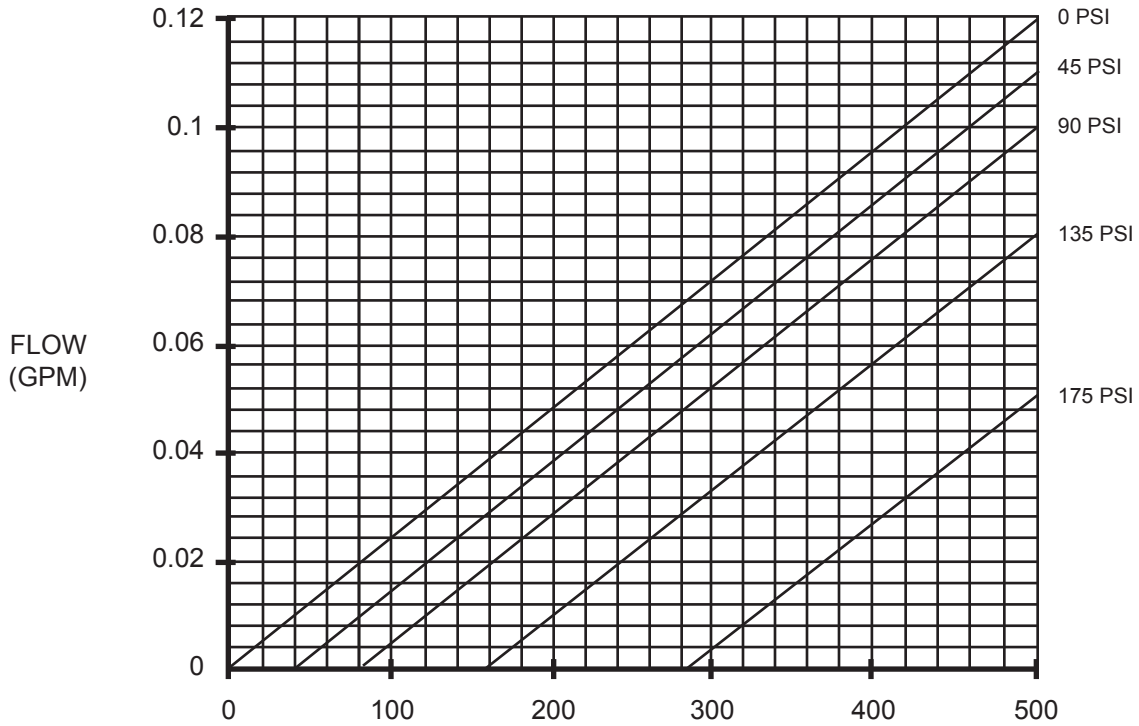

Size: 0.40
Stage(s): 3
Starting Torque = 0.4 to 0.9 ft. lb
Max Pres. = 175 PSI
RPM = 0 - 500

[BACK TO TOP](#)



ADPL SERIES - ADPL 0.40.3

Progressive Cavity Pump

Dimensional Drawings

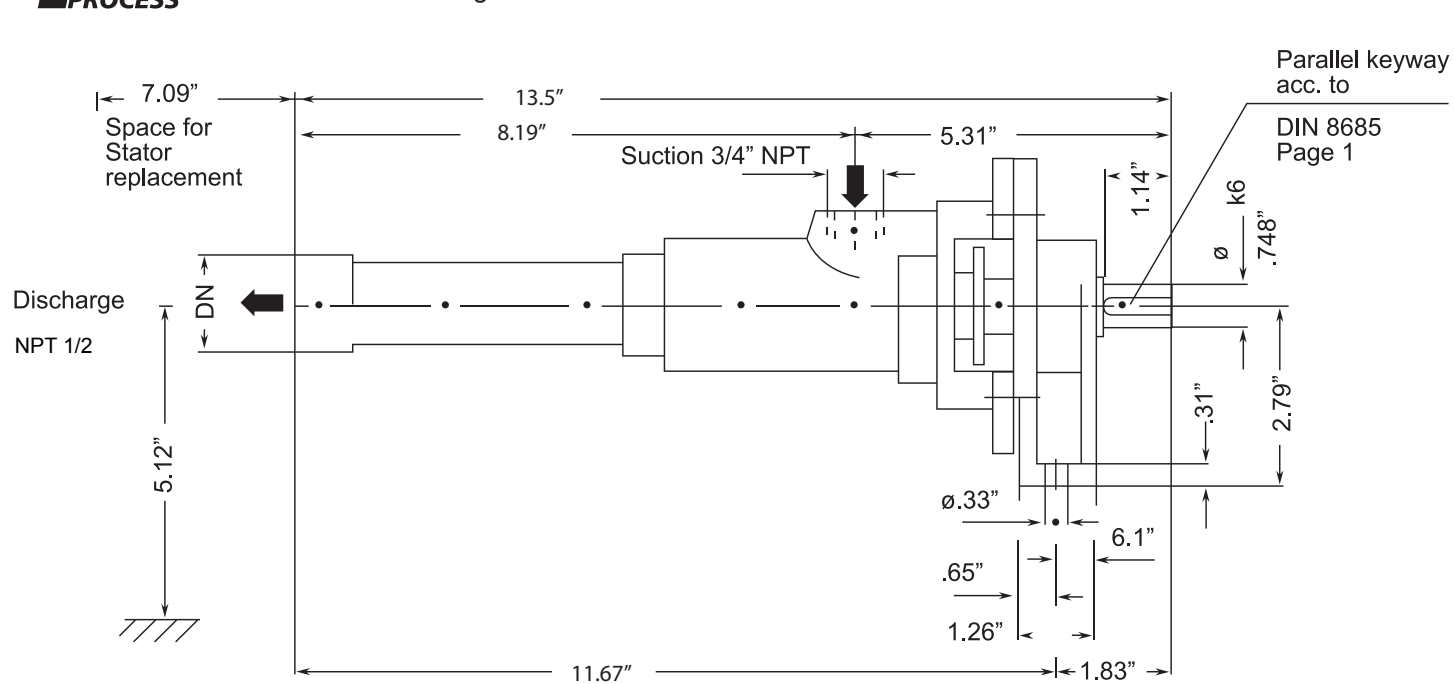

Parallel keyway
acc. to
DIN 8685
Page 1

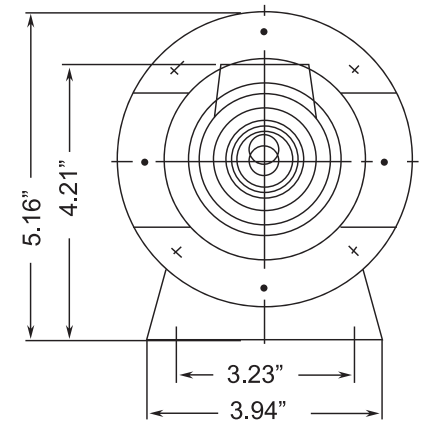

Possible port positions
looking from drive end

1 = Standard

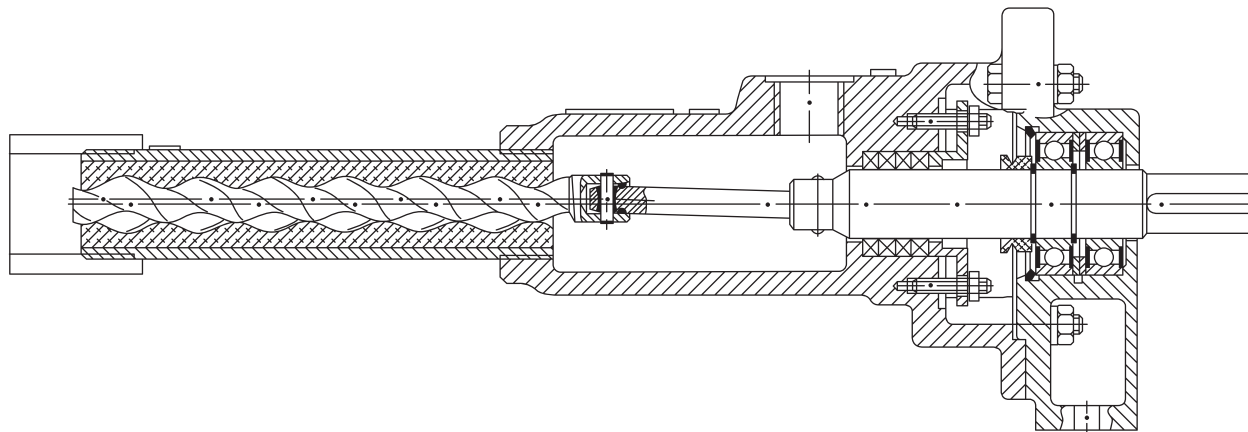
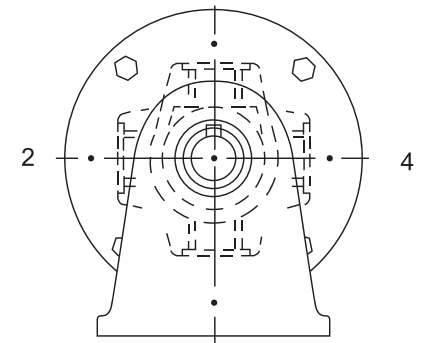

BACK TO TOP

3 Stage Pump

Net weight

≈ lbs.

Inches

7.3

P: 847.640.7867 F: 847.640.7855
2525 Clearbrook Drive Arlington Heights, IL 60005

www.libertyprocess.com