

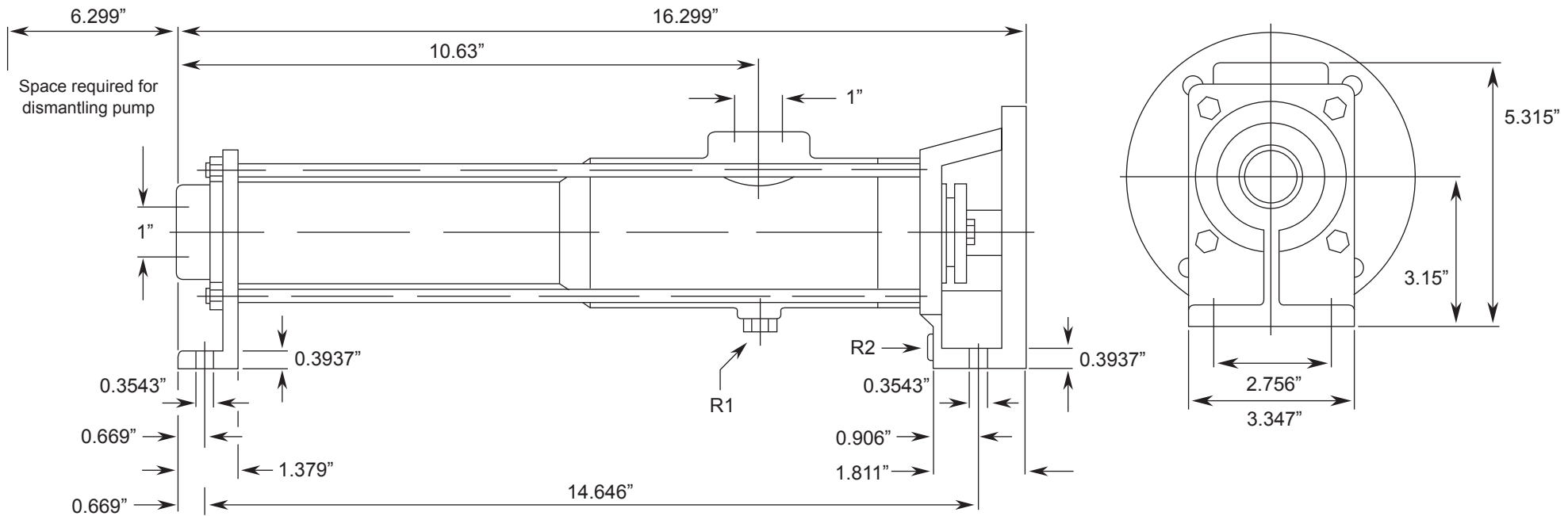

# ANBPL SERIES - ANBPL 3.2

Progressive Cavity Pump

Dimensional Drawings



Net weight

≈ lbs.

**11.0**

ALL DIMN: Inches

## 2 Stage Pump

Direction of rotation: Counterclockwise looking from the drive end is standard, in which case DN1 = delivery connection, DN2 = suction connection. Opposite direction of rotation is possible in which case DN1 = suction connection, DN2 = delivery connection.

P: 847.640.7867 F: 847.640.7855  
2525 Clearbrook Drive Arlington Heights, IL 60005

[www.libertyprocess.com](http://www.libertyprocess.com)