

SECTION "A - A"

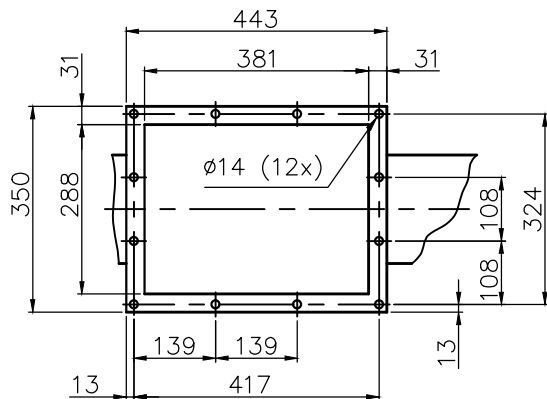
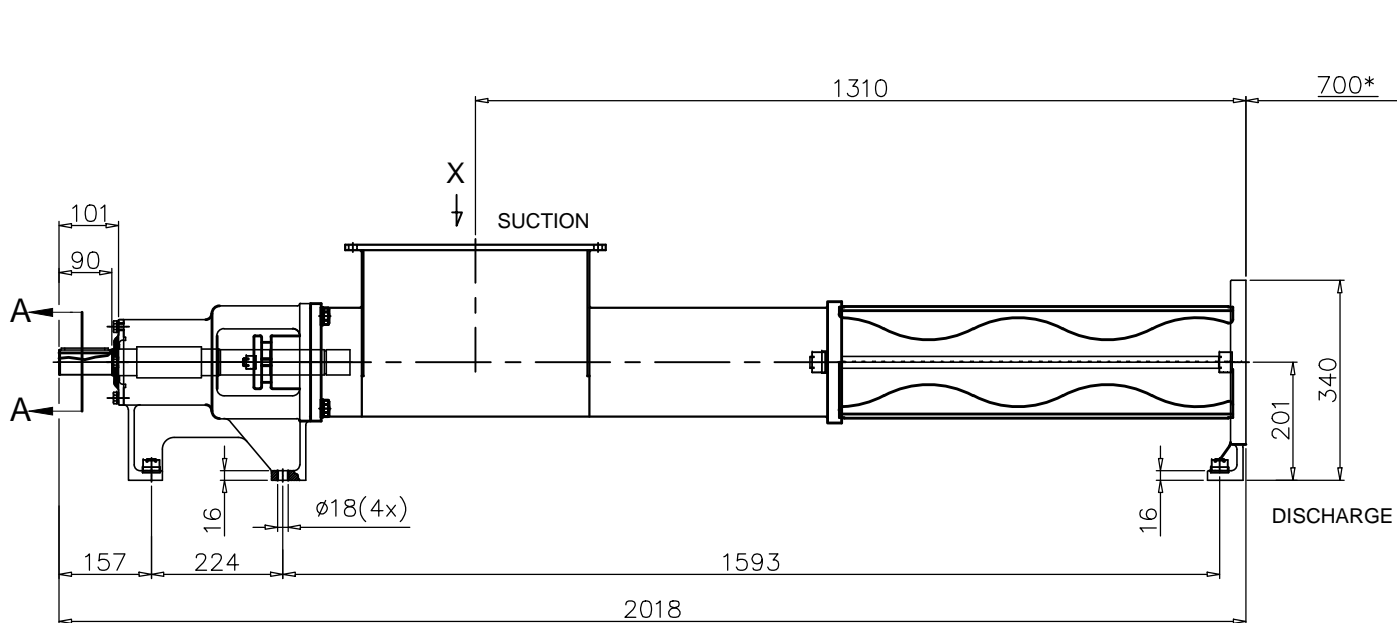

DETAIL "X"
SUCTION FLANGE

DISCHARGE : FLANGE 6" ANSI B16.5 - 150 LB - FF

*OBS:
- MINIMUM SPACE REQUIRED FOR DISASSEMBLE

FROM	---	6	30	100	300	1000	2000	4000	◎ CONCENTRICITY
TO	6	30	100	300	1000	2000	4000	---	∥ PARALLELISM
DEVI.	±0,1	±0,2	±0,3	±0,5	±0,8	±1,2	±2	±3	⊥ ORTHOGONALITY
SURFACE FINISH		~	▽	▽▽	▽▽▽	▽▽▽▽	TRIM NON INDICATED EDGES		
ROUGHNESS RA U M		25	12	3	0,8	0,2			
MAT.: SEE TABLE		EXEC.		DATE:		NAME:			
DIM.: NA		DRA.		08/01/20		DOUGLAIL			
PROD.: HTV-76I		APR.		08/01/20		DOUGLAIL			
POS.:		ESC.:		S/E					

THIS DRAWING CAN NOT BE REPRODUCED ALL OR PART, OR CIRCUMSTANT TO THIRD PARTIES WITHOUT OUR WRITTEN AUTHORIZATION.



CODE XXXXXXXXXXXX REV. 00

PUMP DIMENSIONAL DRAWING